

(12) UK Patent Application

(19) GB

(11) 2 209 682 A<sup>(13)</sup>

(43) Date of printing by UK Office 24.05.1989

(21) Application No 8824664.0

(22) Date of filing 09.07.1987

(30) Priority data  
(31) 8616818 (32) 10.07.1986 (33) GB

(86) International application data  
PCT/GB87/00482 En 09.07.1987

(87) International publication data  
WO88/00491 En 28.01.1988

(51) INT CL<sup>4</sup> (as given by ISA)  
A63H 31/00

(52) UK CL (Edition J)  
A6S S19D2 S19D3B

(56) Documents cited by ISA  
DE 2046286 A DE 1197365 B FR 1304969 A

(58) Field of search by ISA  
INT CL<sup>4</sup> A63H

(71) Applicant  
Britains Petite Limited

(Incorporated in the United Kingdom)

Blackhorse Lane, Walthamstow, London, E17 5QD,  
United Kingdom

(72) Inventor  
Alojzy Matejczyk

(74) Agent and/or Address for Service  
J Y & G W Johnson  
Furnival House, 14-18 High Holborn, London,  
WC1V 6DE, United Kingdom

(54) A toy or model vehicle

(57) A toy or model vehicle, e.g. a tractor, comprises a chassis (1), drive wheel means supported by the chassis (1) and including a drive axle (45) and a first gear means (44), a step-down gear train (30-43) including second gear means (43) and a power take-off shaft (4) extending from the chassis (1) and arranged to be driven by an electric motor (18) via the gear train (30-43). Manually operable clutch means (50) are provided to enable relative movement of the first and second gear means (44 and 43) into or out of meshing engagement to enable or disable the transmission of motive drive to the drive wheel means. The invention also relates to a toy tractor system including a toy tractor having a power take-off shaft and flexible tubing for providing a detachable flexible drive connection between the power take-off shaft and a rotatable shaft or accessory apparatus.

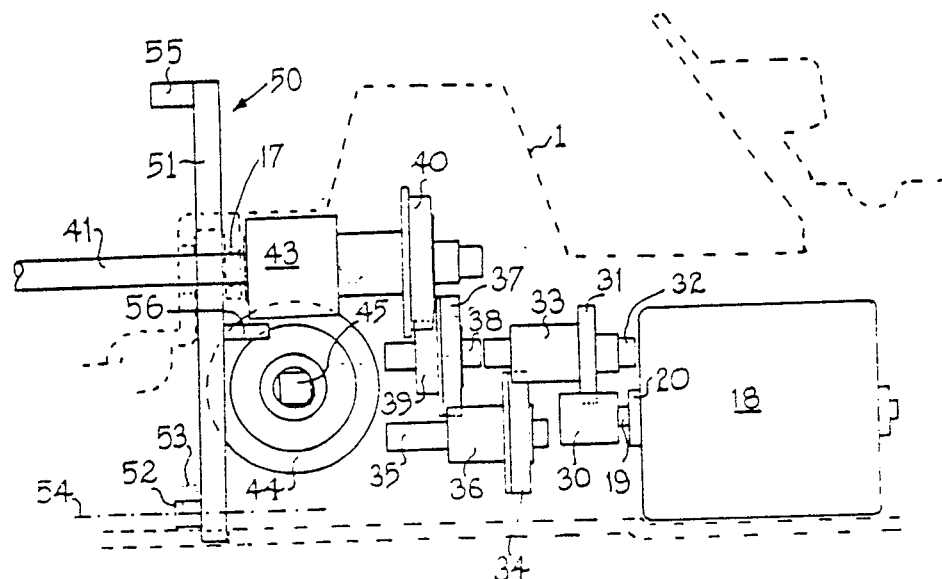

GB 2 209 682 A