



PATENT SPECIFICATION

DRAWINGS ATTACHED

1.159,349

Date of Application and filing Complete Specification: 23 April, 1968.

No. 19013/68.

Application made in South Africa (No. 2411) on 25 April, 1967.

Complete Specification Published: 23 July, 1969.

© Crown Copyright 1969.

Index at acceptance:—A6 S26D

Int. Cl.:—F 41 b 7/02

COMPLETE SPECIFICATION

Toy Gun

We, BRITAINS LIMITED, a British Company, of Blackhorse Lane, London, E.17 (formerly of 186 King's Cross Road, London, W.C.1.), do hereby declare the invention, for which we pray that a Patent may be granted to us, and the method by which it is to be performed, to be particularly described in and by the following Statement:—

This invention relates to toys. More particularly it relates to a toy gun for projecting elastic bands.

The well-known method of projecting an elastic band consists in stretching the band over a longitudinal body and then releasing the rear end of the band from the body. Toy guns embodying this principle have been known for many years. The invention relates to a toy gun which is capable of being loaded with several bands so that it can project the bands in rapid succession.

According to the invention a toy gun comprises a body having a primary recess adapted to accommodate the rear end of a stretched elastic band, means to disengage the band from the primary recess to project the band away from the gun, a series of secondary recesses in the vicinity of the primary recess each of which is adapted to accommodate the rear end of a stretched elastic band, and means operative to transfer each band in a secondary recess to the next adjacent secondary recess closer to the primary recess or to the primary recess so that as a band is displaced from the primary recess another band takes its place.

Preferably the means for disengaging a band from the primary recess is adapted to be actuated by a trigger on the gun.

Conveniently the transferring means is also adapted to be actuated by a trigger on the gun.

One embodiment of toy gun in accordance with the invention will now be described, by way of example, with reference to the accompanying drawings, in which:—

Figure 1 is a side elevation of the gun,

Figure 2 is a view from above of the gun of Figure 1, and

Figures 3 and 4 are partial side elevations showing how elastic bands are fired from the gun. 45

Referring to the drawings, the gun comprises a body 1 in the form of a barrel and a butt and having a bifurcated rear end defining two spaced limbs 2 and 3. Primary body slots 4 and secondary body slots 5, 6 and 7 are formed in both limbs so that an elastic band stretched around the barrel portion of the body can be retained in tension in an indentation 8 at the front end of the barrel and in each of the body slots 4 to 7. 55

A flat firing plate 9 is mounted for sliding movement between the limbs 2 and 3 at the rear end of the gun. The rear edge of the firing plate 9 is provided with plate slots 10, 11 and 12 similar to the secondary body slots 5, 6 and 7 in the limbs but staggered thereto. The firing plate 9 includes a trigger 13 so that when the trigger 13 is pulled the firing plate 9 is moved backwards to protrude from the rear edge of the gun. The firing plate is biased to its normal position by an elastic band 14 so that when the trigger is released, the firing plate 9 moves back into its original position between the limbs 2 and 3. 65 70

In use, the gun is loaded with several bands as described above. When the trigger 13 is pulled the firing plate 9 disengages the uppermost band from the primary body slot 4 which causes the band to be projected away from the gun (as shown in Figure 3). At the same time all the other bands are lifted out of their secondary gun slots 5, 6 and 7 by the firing plate 9 and when the trigger 13 is released each band will fall back into the body slot adjacent to the original slot occupied by that band and closer to the primary slot 4, due to the staggered relationship between the body slots 5 to 7 and the plate slots 10 to 12. Thus when the trigger is released another band will have been transferred to the primary 75 80 85

body slot 4 (as shown in Figure 4) from which it can be projected by pulling the trigger again. Bands can therefore be projected from the gun in rapid succession simply by pulling the trigger until all the bands have been used.

Although the embodiment illustrated can fire only four bands successively without reloading, it will be appreciated that this number can be any number greater than three, although, in practice, it is unlikely that a capacity in excess of six bands per loading would be necessary.

The particular embodiment of gun shown in the drawing can easily be fabricated in three pieces from a plastics material, one piece being the firing plate 9 slidably received in a recess formed between two body parts clipped together by locating pins 15.

WHAT WE CLAIM IS:—

1. A toy gun comprising a body having a primary recess adapted to accommodate the rear end of a stretched elastic band, means to disengage the band from the primary recess to project the band away from the gun, a series of secondary recesses in the vicinity of the primary recess each of which is adapted to accommodate the rear end of a stretched elastic band, and means operative to transfer each band in a secondary recess closer to the primary recess or to the primary recess to the next adjacent secondary recess so that as a band is displaced from the primary recess another band takes its place.

2. A toy gun as claimed in claim 1, in which the body has a barrel and a butt, the end of the barrel remote from the butt having means for locating the front end of the bands.

3. A toy gun as claimed in claim 1 or claim 2, in which the means for disengaging a band from the primary recess is adapted to be actuated by a trigger on the gun.

4. A toy gun as claimed in claim 3, in which the transferring means is also adapted to be actuated by a trigger of the gun.

5. A toy gun as claimed in any of the preceding claims, in which the body includes a cavity in which the transferring means is slidably located.

6. A toy gun as claimed in any of the preceding claims, in which the body and its associated transferring means are fabricated from plastics material.

7. A toy gun as claimed in claim 5, in which the transferring means is biased into its normal position by a separate elastic band.

8. A toy gun substantially as hereinbefore described with reference to, and as illustrated in, the accompanying drawings.

J. Y. & G. W. JOHNSON,
Furnival House,
14—18, High Holborn,
London, W.C.1.
Chartered Patent Agents,
Agents for the Applicants.

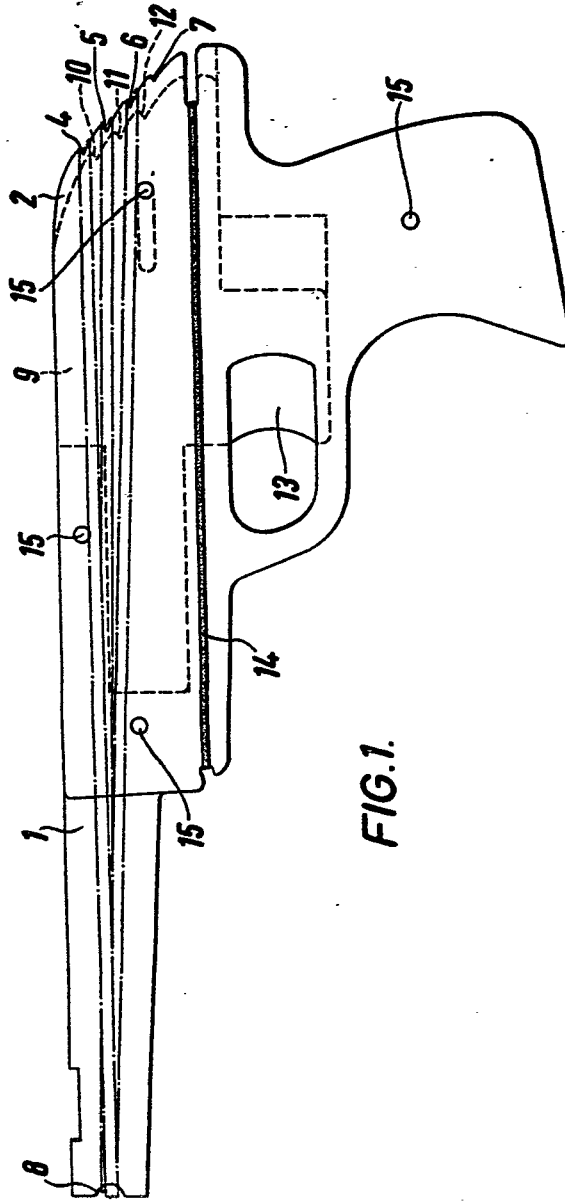

FIG. 1.



FIG. 2.

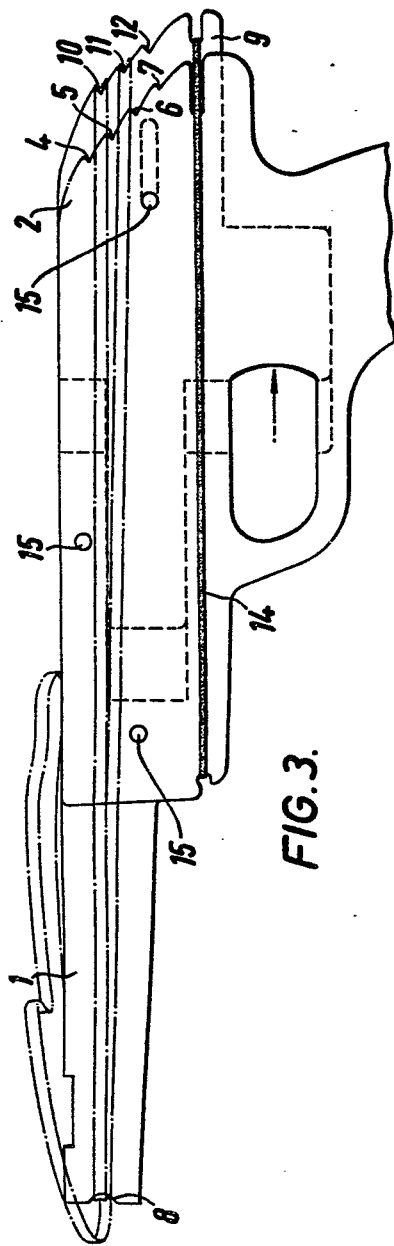

FIG. 3.

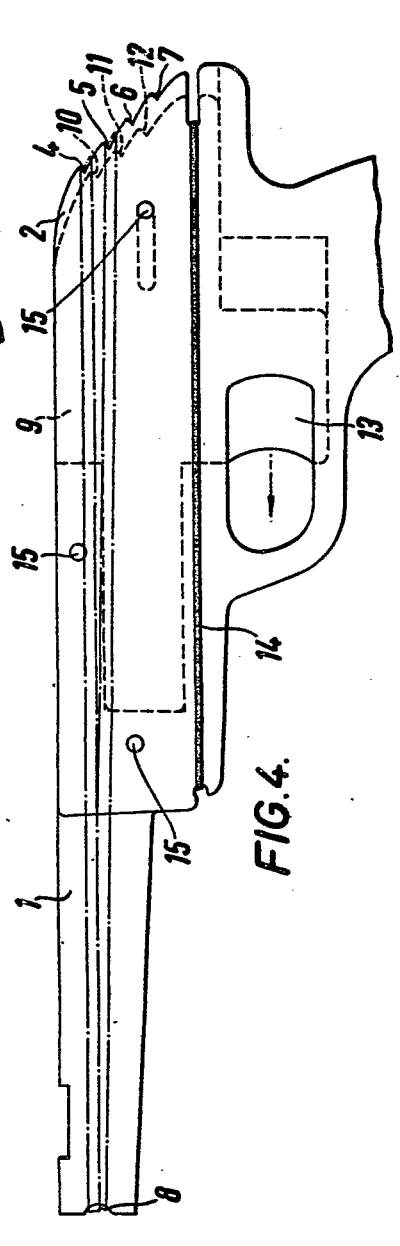

FIG. 4.