

PATENT SPECIFICATION



Convention Date (Germany) : Nov. 18, 1937.

521,348

Application Date (in United Kingdom) : Nov. 14, 1938. No. 33065/38.

Complete Specification Accepted : May 20, 1940.

COMPLETE SPECIFICATION

Improvements in or relating to Toy Electric Railways

I, ERNST VOELK, German citizen, sole personally responsible partner of Vereinigte Spielwarenfabriken Andreas Förtner & J. Haffner's Nachfolger (a Kommanditgesellschaft registered under the Laws of Germany) of 10, Schillerstrasse, Nuremberg, Germany, do hereby declare the nature of this invention and in what manner the same is to be performed, to be particularly described and ascertained in and by the following statement:—

The invention relates to toy electric railways, and especially to toy locomotives, motor trucks, tenders and the like, and concerns the insulation of the track wheels of same.

The current taken up by the track wheels from the feed rails, must not flow into the other parts; and, in particular, must not be conducted further through the gear wheels transmitting rotational movement to the other track wheel axles.

In a known arrangement, the track wheels are seated on bushes of non-conductive material, and the gear wheels located on the inside of the track wheels are also of non-conductive material. Since, owing to the small space available these latter can be only very weak, their working life is short by comparison with the other parts. It is also disadvantageous that the gudgeon pins of the crank rods must also be insulated at the various points of attachment, and this is a rather difficult matter owing to the small dimensions of these members, and very troublesome by reason of the number of insulations required.

In the case of a toy railway designed in accordance with the invention, these drawbacks are remedied by arranging a disc of non-conductive material on the inner side of the rim of each track wheel, or by making the rim itself of non-conductive material; or also, by inserting an insulating plate on the outer side of each track wheel, between this and a disc serving to mount the gudgeon pin of the crank rod. This insulating plate is preferably secured to the track wheel by pressure.

The new design of the track wheel insulation enables metal gear wheels to be employed for transmitting the rota-

tional movement of the driven track wheel axle to the other track wheel axles, premature wear of these gear wheels, in relation to the other parts being thus prevented. At the same time, none of the small amount of space available is needed for the insulation, since the rim effects the insulation. Another advantage consists in that special insulation of the various crank-rod gudgeon pins is superfluous, whilst, nevertheless, a guarantee is afforded that these latter do not receive any current.

The invention will be clearly understood from the following description aided by the accompanying drawings in which:—a typical embodiment of the invention is illustrated and, in which: Figure 1 is a side elevation of a toy locomotive; Figure 2 a section through a track wheel, with a plan of the adjoining track wheel, and Figure 3 a section through another embodiment of a track wheel.

The locomotive *a* is provided with three pairs of track wheels *b*, mounted on the axles *c*. The wheels *b* are seated on bushes *h*, of non-conductive material. The gear wheels *e* and *f* serve to transmit the rotational movement of the driven track wheel axle to the axles of the other track wheels.

The rim *b'* of the track wheels *b* is partially (see Figure 2) or wholly (see Figure 3) constructed of a disc *g* of non-conductive material. This enables the gear wheels *e* and *f* to be made of metal, whilst no portion of the small space available between the track wheels *b* and the undercarriage *o* is required for the insulation.

Inserted on the outer side of each wheel *b*, and between this and a disc *k*, which receives the gudgeon pin *d* of the crank rod, is a plate *i* of non-conductive material. In this manner any passage of current from the wheels *b* to the crank rods is precluded. There is therefore no need for the individual insulation of the several gudgeon pins.

The insulating plate *i* is provided with a recess *l* in which lies the member—rivet head *p* in the example shown—securing the gudgeon pin *d*.

It is of particular advantage that the insulating plate *i* should be provided with

a projection or the like *m*, which can be formed, at the same time as the recess *l* by pressing. This protection enters a corresponding recess in the wheel, 5 thereby preventing the insulating plate *i* from turning in relation to the wheel.

Having now particularly described and ascertained the nature of my said invention and in what manner the same is to 10 be performed, I declare that what I claim is:—

1. Vehicles for toy electric railways, especially toy locomotives, motor trucks, 15 tenders, or the like, with insulated track wheels, characterised in that the rim of each track wheel seated on a bush of non-conductive material, is partially or wholly formed of a disc of non-conductive material.

20 2. Toy electric vehicle according to Claim 1, characterised in that a plate of non-conductive material is inserted, on the outer side of each track wheel between

this and a disc serving to mount the gudgeon pin of the crank rod. 25

3. Toy electric vehicle according to Claim 2, characterised in that the insulating plate is provided with a recess which accommodates the member—such as a rivet head—securing the gudgeon pin. 30

4. Toy electric vehicle according to Claims 2 and 3, characterised in that the insulating plate is prevented, by means of a projection, lug or the like, engaging in a recess in the track wheels from turning 35 in relation to the latter.

5. Toy electric railway wheels, constructed substantially as described with reference to the accompanying drawings.

Dated this 14th day of November, 1938.

H. GARDNER & SON,
Chartered Patent Agents.

173-4-5, Fleet Street,
London, E.C.4.

Agents for the said Applicant.

Fig.1

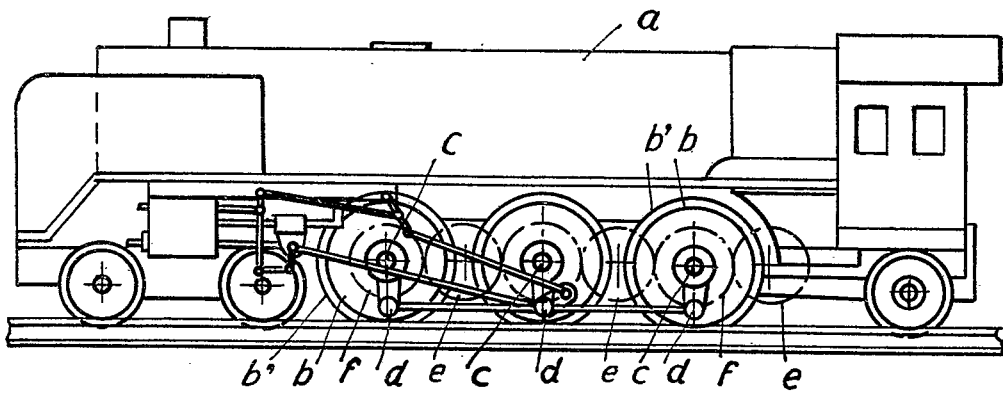

Fig.2

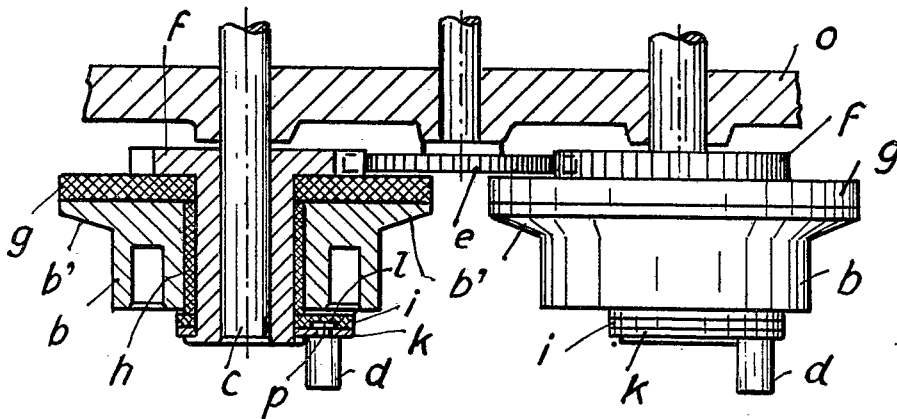
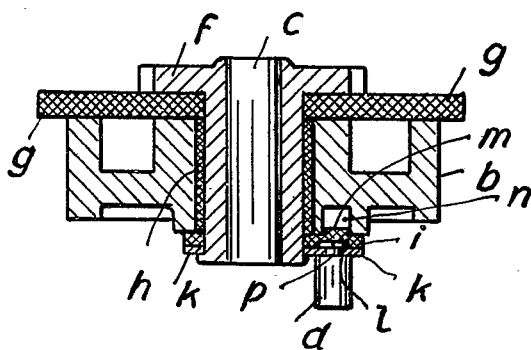

Fig.3



[This Drawing is a reproduction of the Original on a reduced scale.]